



# :LYPL;B;14D

DESIGN MATTEO THUN & ANTONIO RODRIGUEZ



attacco standard  
standard connection  
raccord standard  
standard Anschluss  
conexión estándar

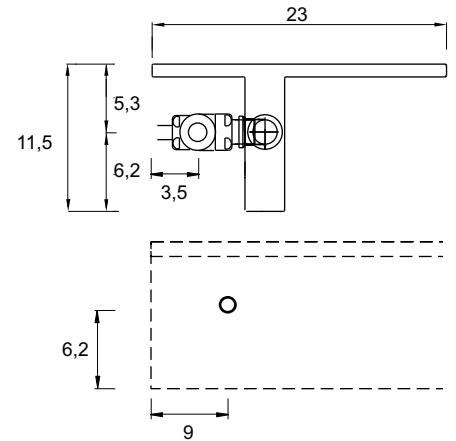
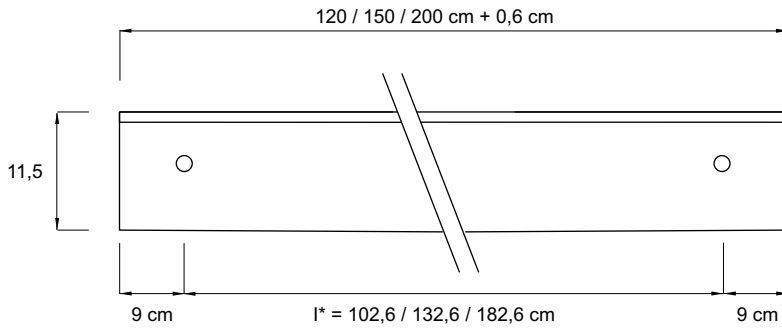
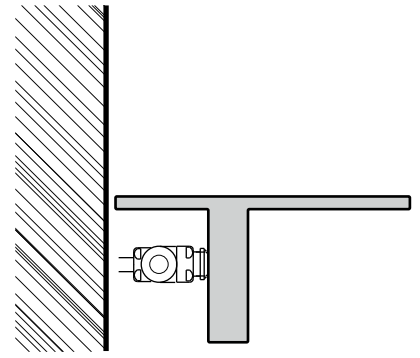

B*		A*		I*		art*	L*	BTU Δt 50°	watt Δt 50°	E* watt
cm	inches	cm	inches	cm	inches					
120.6	47.5	11.5	4.5	102.6	40.4	T100M120B	0.3	1 048	307	190
150.6	59.3	11.5	4.5	132.6	52.2	T100M150B	0.4	1 311	384	370
200.6	79.0	11.5	4.5	182.6	71.9	T100M200B	0.6	1 747	512	500

## Su misura / Tailoring / Sur mesure / Nach Maß / A medida

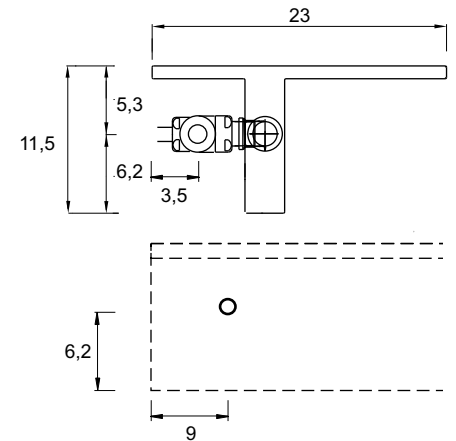
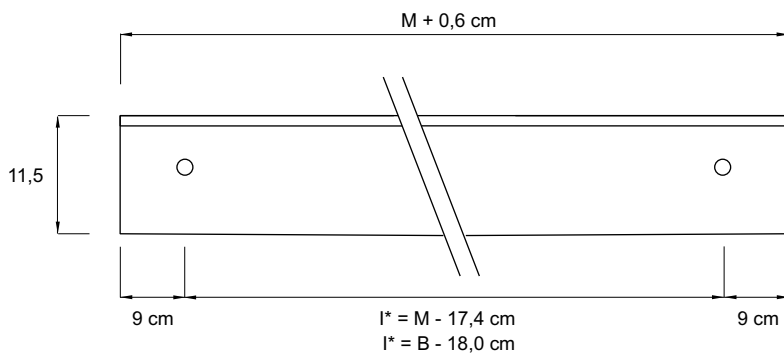

## Su misura / Tailoring / Sur mesure / Nach Maß / A medida

Su misura / Tailoring / Sur mesure / Nach Maß / A medida		art*	watt/cm Δt 50°	E* watt
Da 100 cm >>>	A 119 cm	T100M1_B	2.56	165
Da 121 cm >>>	A 149 cm	T100M1_B	2.56	190
Da 151 cm >>>	A 199 cm	T100M1_B	2.56	370
Da 201 cm >>>	A 250 cm	T100M2_B	2.56	500

A\* = altezza / height / hauteur / Höhe / alto B\* = larghezza / width / longueur / Breite / ancho art\* = articolo / model / modèle / Artikel / artículo  
I\* = interasse / pipe centres / distance entre départ et retour / Achsabstand / distancia entre las conexiones B\* = pagina / page / page / Seite / página  
L\* = contenuto acqua / content / volume / Inhalt / volumen E\* = elettrico / electrical / électrique / elektrisches / eléctrico

Kcal = Watt x 0.860  
BTU = Watt x 3.413

Watt Δt 60° = Watt Δt 50° x 1.245  
Watt Δt 40° = Watt Δt 50° x 0.765  
Watt Δt 30° = Watt Δt 50° x 0.541  
Watt Δt 20° = Watt Δt 50° x 0.332

p max = 6,5 bar

Colori/ colours / couleurs / Farbe / colores

[ BIAN ] B standard  
T + 30%  
S + 30%  
[ RAL ] S + 30%  
RAL non inclusi in tabella  
special Ral colours  
couleurs Ral spéciales  
RAL Farbe nicht in der Tabelle inbegriffen  
colores RAL especiales

AVC0561\_  
AVC0562\_

Valvole incluse  
Valves are included in the price  
Valves incluses dans le prix  
Ventile im Preis inbegriffen  
Valvulas incluidas en el precio

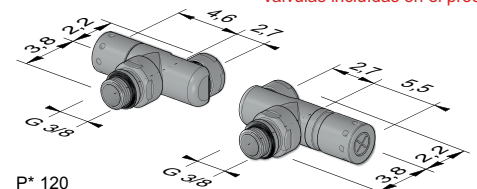

P\* 120

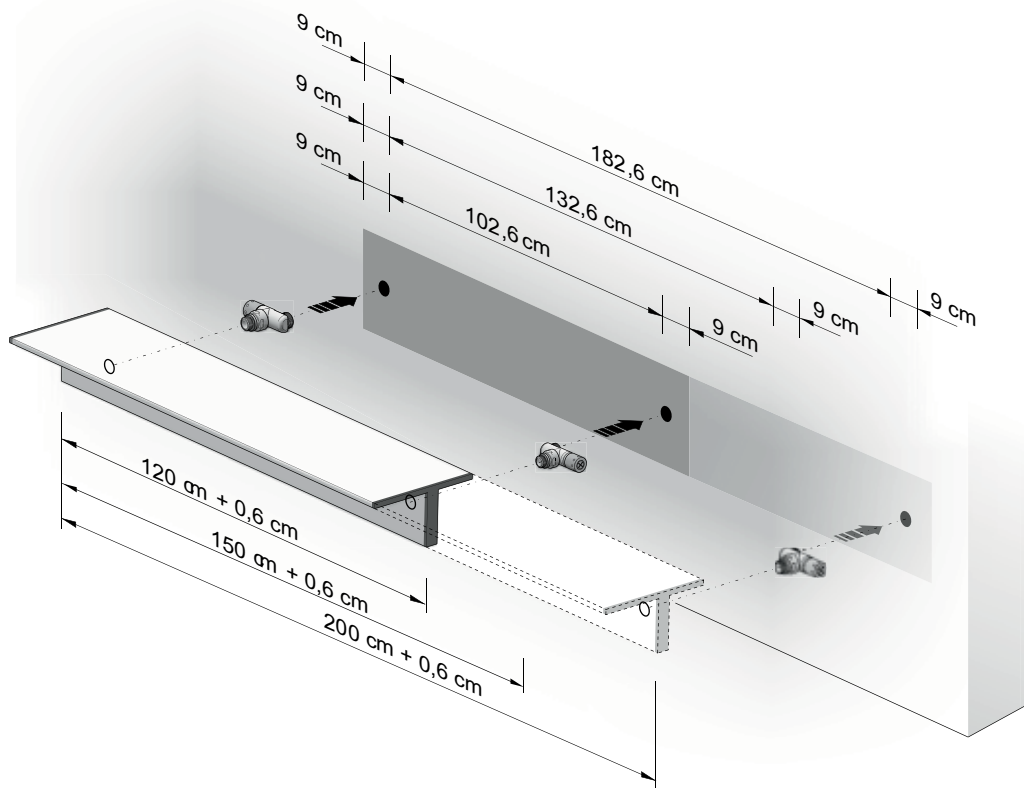

art* cm	B* cm	A* cm	I* cm
T100M120_	120.6	11.5	102.6
T100M150_	150.6	11.5	132.6
T100M200_	200.6	11.5	182.6

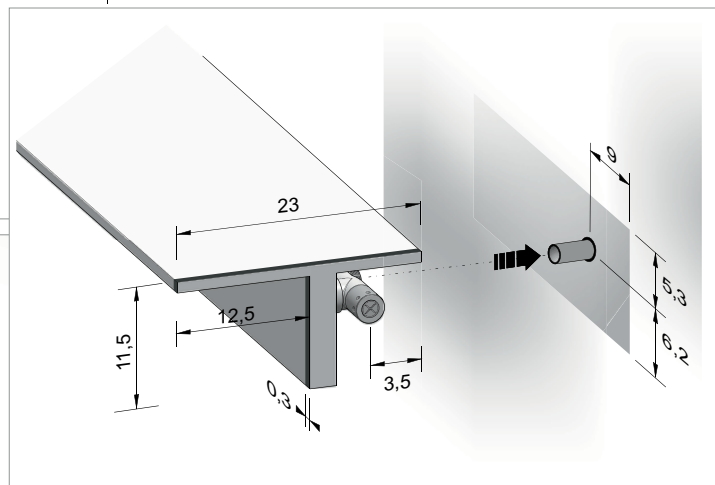

**Su misura / Tailoring / Sur mesure / Nach Maß / A medida**

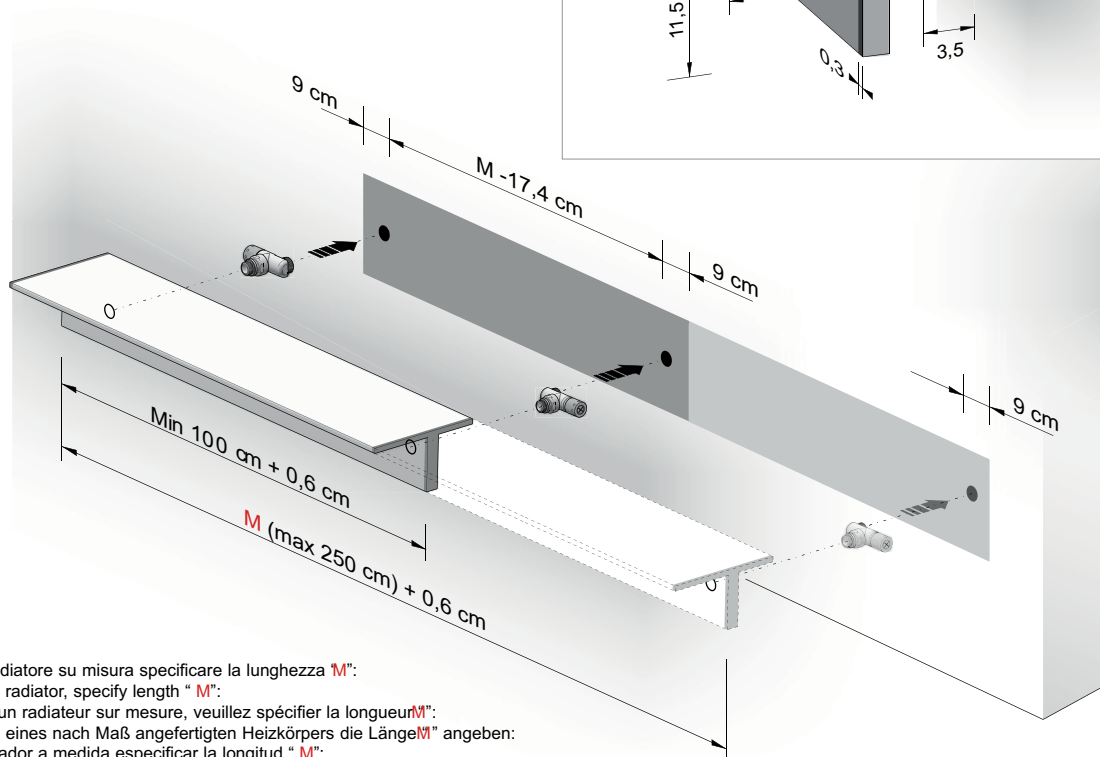

Per ordinare un radiatore su misura specificare la lunghezza "M":  
 To order a tailored radiator, specify length "M":  
 Pour commander un radiateur sur mesure, veuillez spécifier la longueur "M":  
 Bei der Bestellung eines nach Maß angefertigten Heizkörpers die Länge "M" angeben:  
 Para pedir un radiador a medida especificar la longitud "M":

art* cm	M	B* cm	A* cm	I* cm	range
T100M (M)_		B= M + 0.6	11.5	I= M - 17.4	100 --> 119
					121 --> 149
					151 --> 199
					201 --> 250

Informazioni tecniche aggiuntive p.26.  
 Additional technical information p.26.  
 Informations techniques supplémentaires p.26.  
 Zusätzliche technische Informationen s.26.  
 Informaciones técnicas adicionales p.26.

(es: **M=156 cm** --> art\*=T100M156\_ B\*=156.6 A\*=11.5 I\*=138.6 )



# :LYPL;B;17D

DESIGN MATTEO THUN & ANTONIO RODRIGUEZ



attacco standard  
standard connection  
raccord standard  
standard Anschluss  
conexión estándar

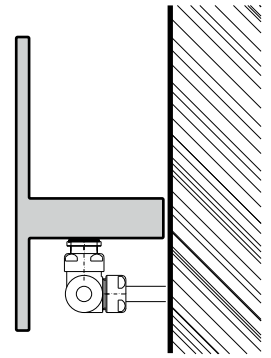

B*		A*		I*		art*	L*	BTU Δt 50°	watt Δt 50°	E* watt
cm	inches	cm	inches	cm	inches					
120.6	47.5	23.0	9.1	108.0	42.5	T100P120B	0.3	1 048	307	190
150.6	59.3	23.0	9.1	138.0	54.3	T100P150B	0.4	1 311	384	370
200.6	79.0	23.0	9.1	188.0	74.0	T100P200B	0.6	1 747	512	500

Su misura / Tailoring / Sur mesure / Nach Maß / A medida

art*		watt/cm Δt 50°		E* watt
Da 100 cm >>> A 119 cm	T100P1_B	2.56		
Da 121 cm >>> A 149 cm	T100P1_B	2.56		190
Da 151 cm >>> A 199 cm	T100P1_B	2.56		370
Da 201 cm >>> A 250 cm	T100P2_B	2.56		500

Fessura portaserviette standard 56 cm / Standard 56 cm towel rail slot	FD056T1P
Fente porte-serviette standard 56 cm / Spalt Handtuchhalter Standard 56 cm	FC056T1P
Ranura toallero estándar 56 cm	FS056T1P
Fessura portaserviette su misura / Tailored towel rail slot	FDXXXT1P
Fente porte-serviette sur mesure / Spalt Handtuchhalter nach Maß	FCXXXT1P
Ranura toallero a medida	FSXXXT1P

A\* = altezza / height / hauteur / Höhe / alto    B\* = larghezza / width / longueur / Breite / ancho    art\* = articolo / model / modèle / Artikel / artículo  
 I\* = interasse / pipe centres / distance entre depart et retour / Achsabstand / distancia entre las conexiones    Ø\* = pagina / page / page / Seite / página  
 L\* = contenuto acqua / content / volume / Inhalt / volumen    E\* = elettrico / electrical / eléctrico / elektrisches / eléctrico

Kcal = Watt x 0.860  
BTU = Watt x 3.413

Watt Δt 60° = Watt Δt 50° x 1.245  
Watt Δt 40° = Watt Δt 50° x 0.765  
Watt Δt 30° = Watt Δt 50° x 0.541  
Watt Δt 20° = Watt Δt 50° x 0.332

p max = 6,5 bar

Colori/ colours / couleurs / Farbe / colores

[ BIAN ] B standard  
T + 30%  
S + 30%

[ RAL ] S + 30%  
RAL non inclusi in tabella  
special Ral colours  
couleurs Ral spéciales  
RAL Farbe nicht in der Tabelle inbegriffen  
colores RAL especiales

AVC0761\_    Valvole incluse  
AVC0742\_    Valves are included in the price  
Valves incluses dans le prix  
Ventile im Preis inbegriffen  
Valvulas incluidas  
en el precio

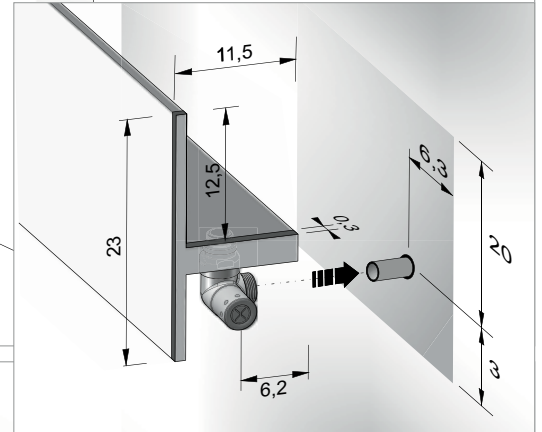
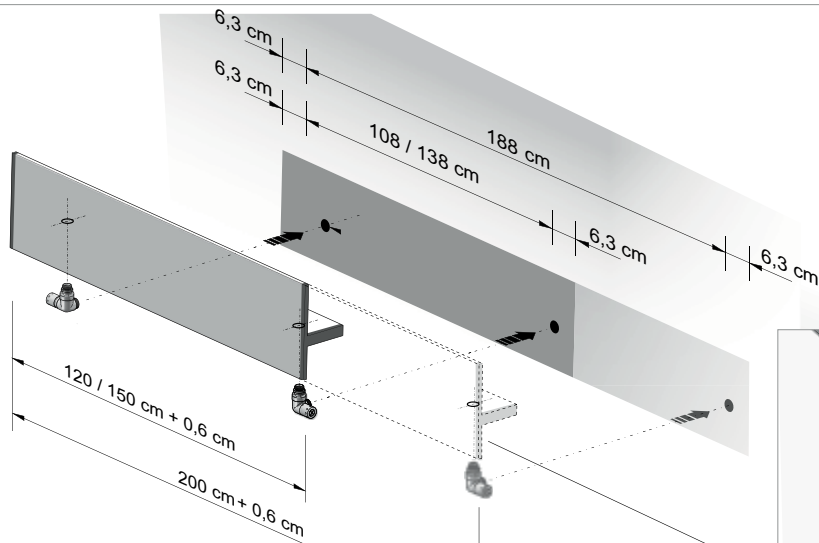

art* cm	B* cm	A* cm	l* cm
T100P120_	120.6	23	108
T100P150_	150.6	23	138
T100P200_	200.6	23	188

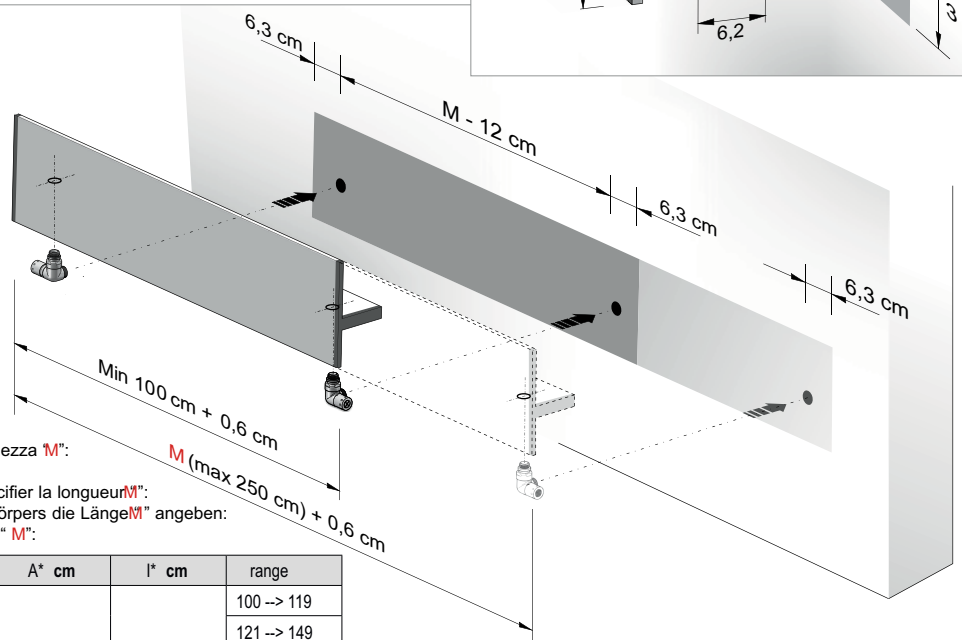

Per ordinare un radiatore su misura specificare la lunghezza "M":  
 To order a tailored radiator, specify length "M":  
 Pour commander un radiateur sur mesure, veuillez spécifier la longueur "M":  
 Bei der Bestellung eines nach Maß angefertigten Heizkörpers die Länge "M" angeben:  
 Para pedir un radiador a medida especificar la longitud "M":

art* cm	M	B* cm	A* cm	l* cm	range
T100P (M)_		B = M + 0.6	23	l = M - 12	100 --> 119
					121 --> 149
					151 --> 199
					201 --> 250

(es: M=156 cm --> art\*=T100P156\_ B\*=156.6 A\*=11.5 l\*=144 )

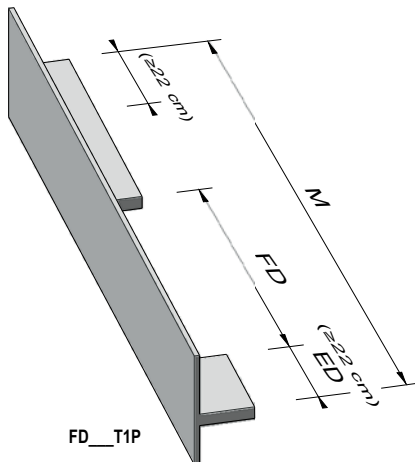

FD\_T1P

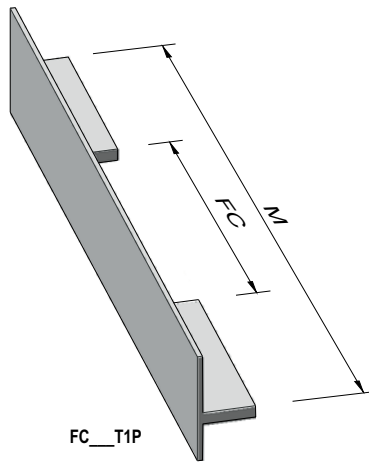

FC\_T1P

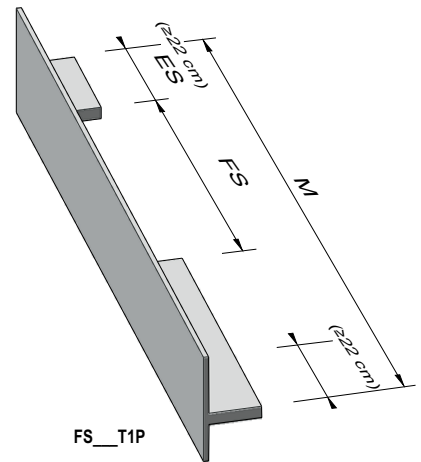

FS\_T1P

Per ordinare l'opzione portasalviette, specificare come segue:  
 To order the towel rail option, specify as follows: / Pour commander l'option porte-serviette, veuillez spécifier comme suit:  
 Bei der Bestellung der Option Handtuchhalter Folgendes angeben: / Para pedir la opción toallero especificar de la forma siguiente:

FD_T1P	FC_T1P	FS_T1P	
ED =		ES =	standard 22 cm
FD =	FC =	FS =	standard 56 cm

Informazioni tecniche aggiuntive p.26.  
 Additional technical information p.26.  
 Informations techniques supplémentaires p.26.  
 Zusätzliche technische Informationen s.26.  
 Informaciones técnicas adicionales p.26.



# :LYPL;B;6D

DESIGN MATTEO THUN & ANTONIO RODRIGUEZ



attacco standard  
standard connection  
raccord standard  
standard Anschluss  
conexión estándar

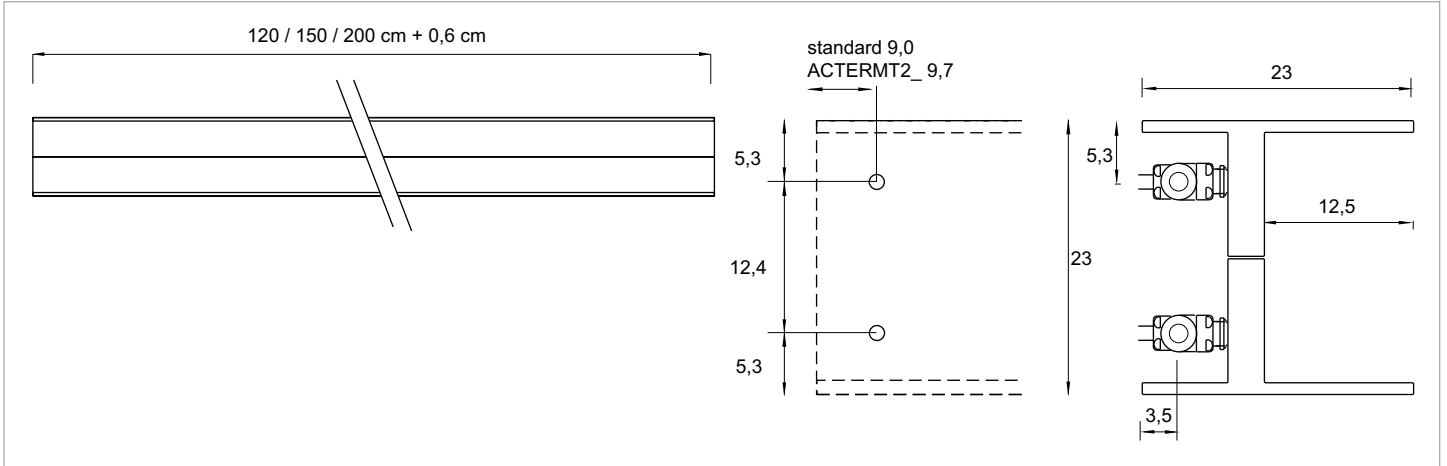
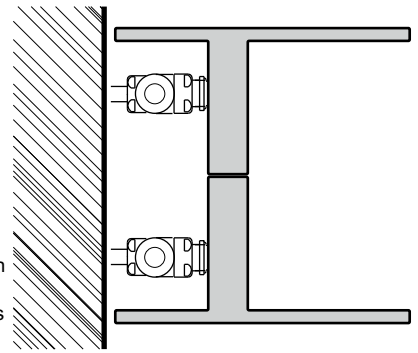

B*		A*		l*		art*	L*	BTU Δt 50°	watt Δt 50°	E* watt
cm	inches	cm	inches	cm	inches					
120.6	47.5	23.0	9.1	12.4	4.9	T200O120B	0.7	2 097	614	380
150.6	59.3	23.0	9.1	12.4	4.9	T200O150B	0.9	2 621	768	740
200.6	79.0	23.0	9.1	12.4	4.9	T200O200B	1.1	3 495	1 024	1 000

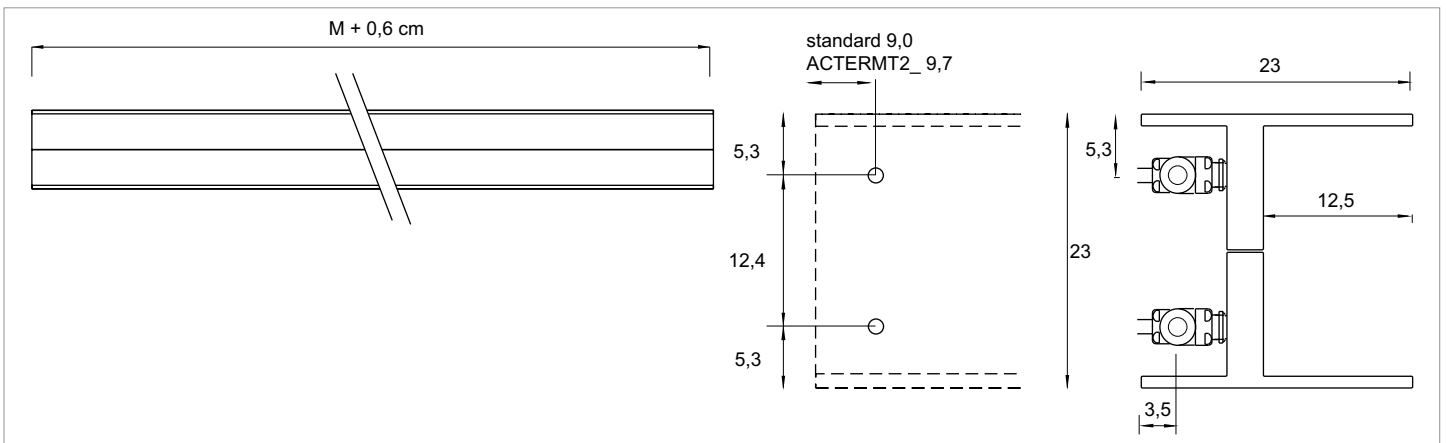

Su misura / Tailoring / Sur mesure / Nach Maß / A medida		art*	watt/cm Δt 50°	E* watt
Da 100 cm >>>	A 119 cm	T200O1_B	5.12	330
Da 121 cm >>>	A 149 cm	T200O1_B	5.12	380
Da 151 cm >>>	A 199 cm	T200O1_B	5.12	740
Da 201 cm >>>	A 250 cm	T200O2_B	5.12	1 000

Terminale opzionale / Optional terminal / Terminal en option / Optionaler Endheizkörper / Terminal opcional	art*	
	ACTERMT2B	2 pz.

A\* = altezza / height / hauteur / Höhe / alto    B\* = larghezza / width / longueur / Breite / ancho    art\* = articolo / model / modèl / Artikel / artículo  
 l\* = interasse / pipe centres / distance entre depart et retour / Achsabstand / distancia entre las conexiones    E\* = pagina / page / page / Seite / página  
 L\* = contenuto acqua / content / volume / Inhalt / volumen    E\* = elettrico / electrical / électric / elektrische / eléctrico

Kcal = Watt x 0.860  
 BTU = Watt x 3.413

Watt Δt 60° = Watt Δt 50° x 1.245  
 Watt Δt 40° = Watt Δt 50° x 0.765  
 Watt Δt 30° = Watt Δt 50° x 0.541  
 Watt Δt 20° = Watt Δt 50° x 0.332

p max = 4 bar

Colori/ colours / couleurs / Farbe / colores

[ BIAN ] B standard  
 T + 30%  
 S + 30%

[ RAL ] S + 30%  
 RAL non inclusi in tabella  
 special Ral colours  
 couleurs Ral spéciales  
 RAL Farbe nicht in der Tabelle inbegriffen  
 colores RAL especiales

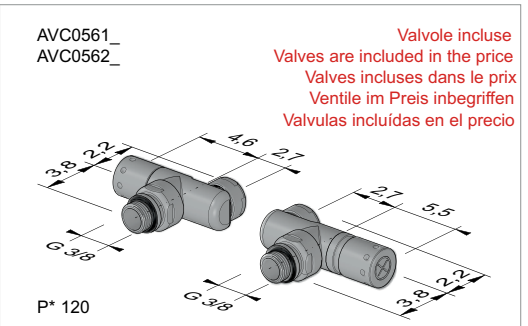

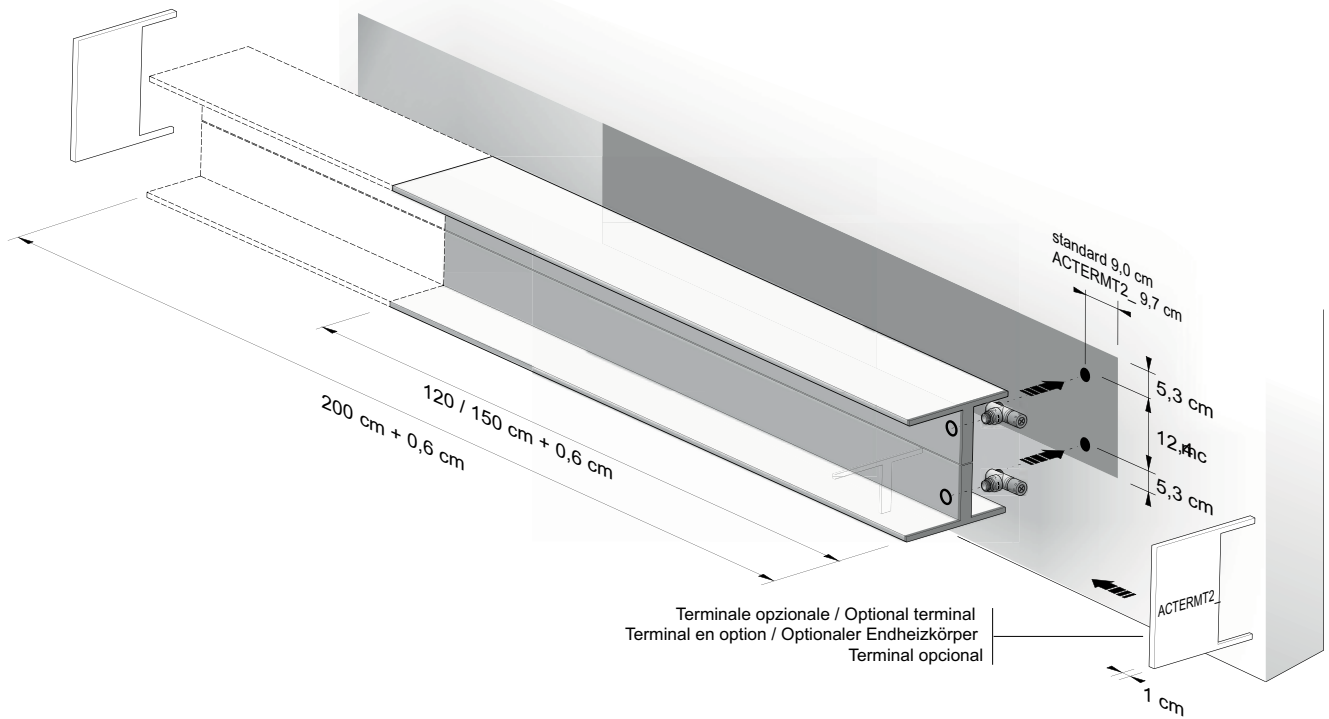

art* cm	B* cm	A* cm	l* cm
T200O120_	120.6	23	12.4
T200O150_	150.6	23	12.4
T200O200_	200.6	23	12.4

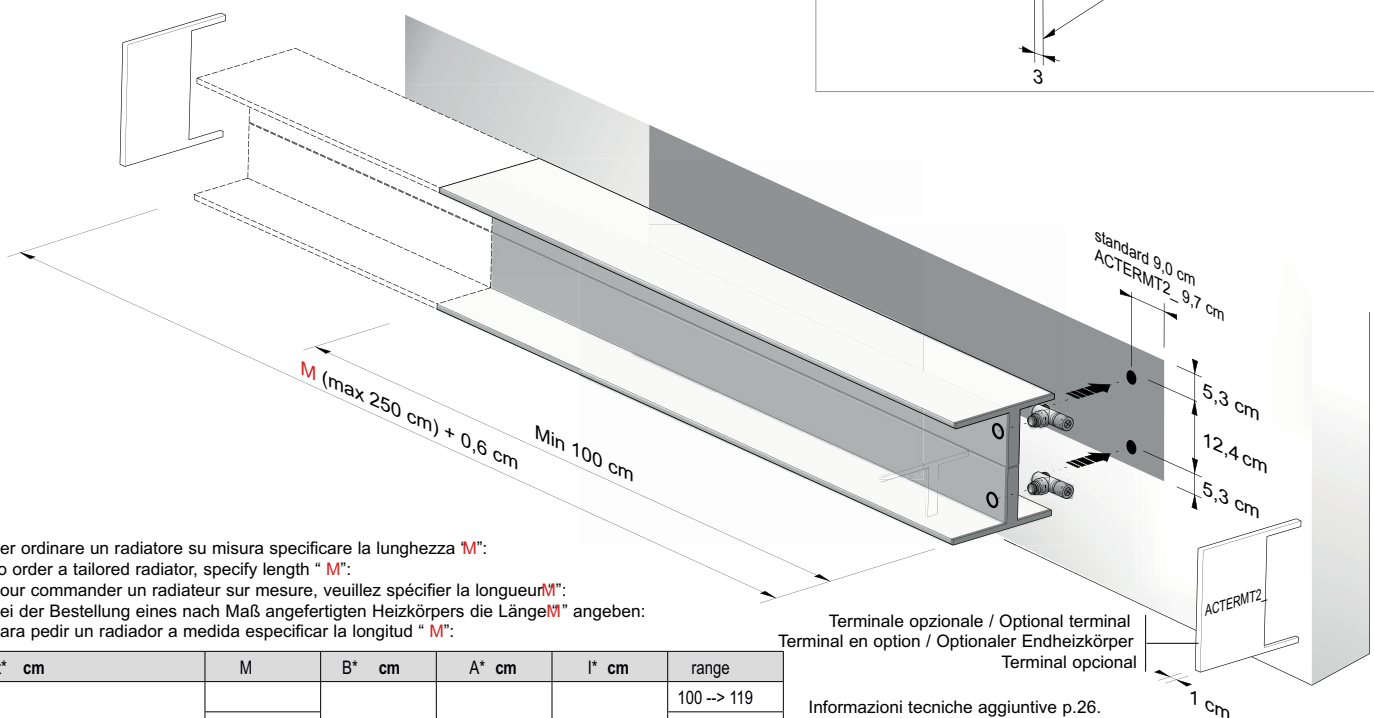
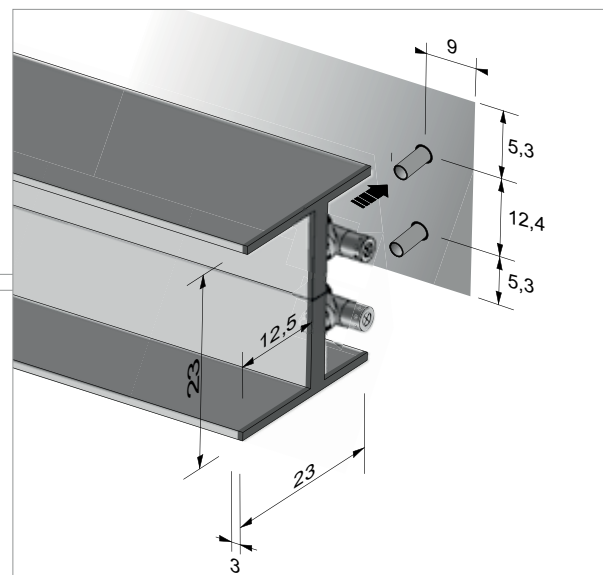

Per ordinare un radiatore su misura specificare la lunghezza "M":  
 To order a tailored radiator, specify length "M":  
 Pour commander un radiateur sur mesure, veuillez spécifier la longueur "M":  
 Bei der Bestellung eines nach Maß angefertigten Heizkörpers die Länge "M" angeben:  
 Para pedir un radiador a medida especificar la longitud "M":

art* cm	M	B* cm	A* cm	l* cm	range
T2000 (M)_		B = M + 0.6	23	12.4	100 -> 119
					121 -> 149
					151 -> 199
					201 -> 250

Informazioni tecniche aggiuntive p.26.  
 Additional technical information p.26.  
 Informations techniques supplémentaires p.26.  
 Zusätzliche technische Informationen s.26.  
 Informaciones técnicas adicionales p.26.

(es: M=198 cm ---> art\*=T200O198\_ B\*=198.6 A\*=23 l\*=12.4 )





## :LYPL;B;=D

DESIGN MATTEO THUN &amp; ANTONIO RODRIGUEZ



attacco standard  
standard connection  
raccord standard  
standard Anschluss  
conexión estándar

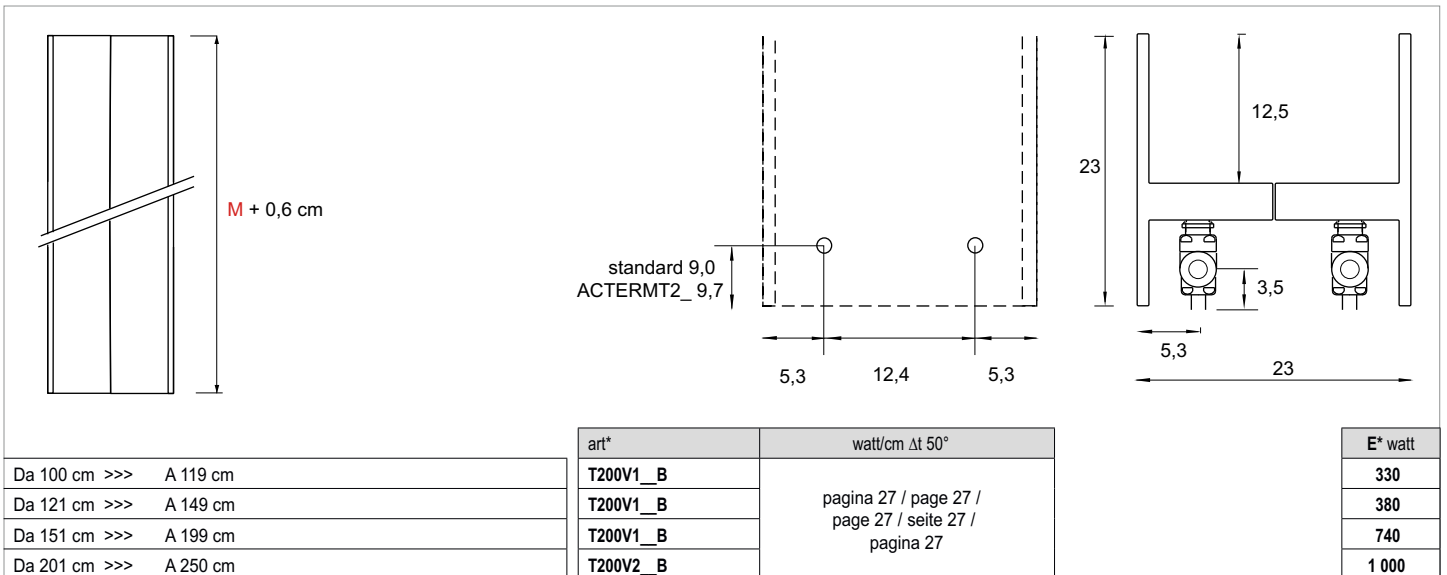
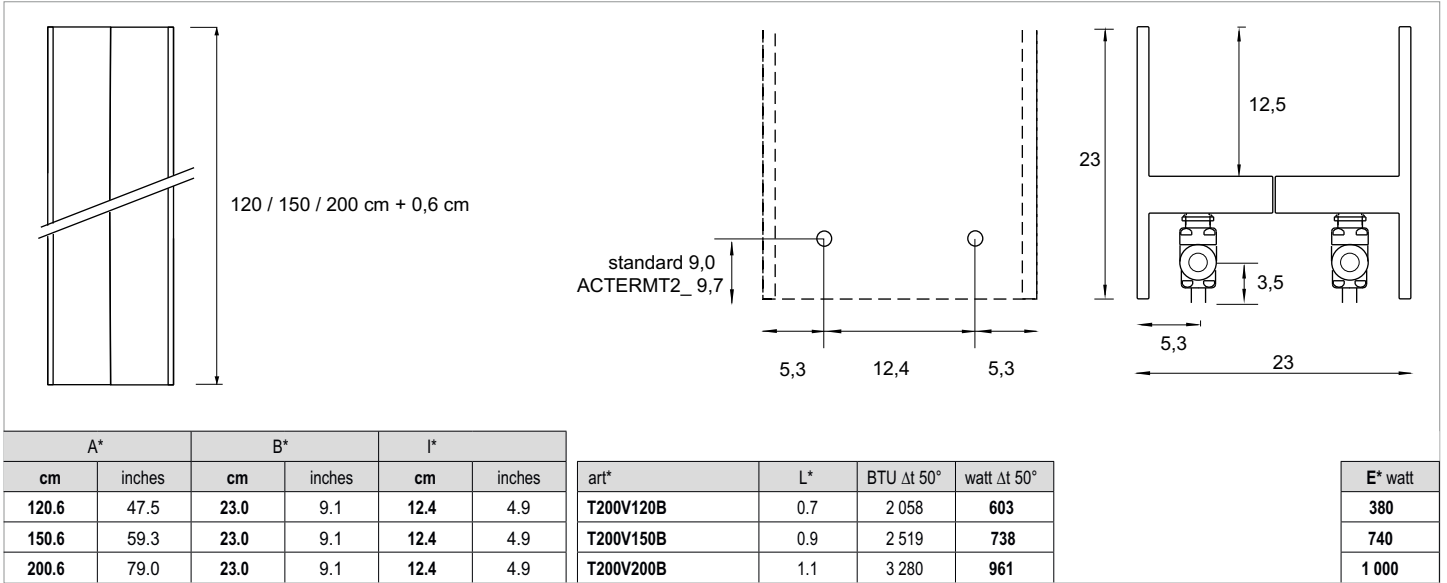
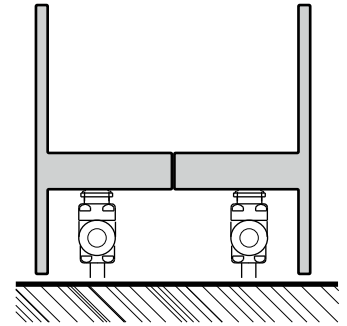

Terminale opzionale / Optional terminal / Terminal en option / Optionaler Endheizkörper / Terminal opcional

Mensole / Shelves / Étagères / Regale / Repisas

Porta accappatoio / Bathrobe holder / Bademantelträger / Porte-peignoir / Perchero para albornoces

ACTERM2B 2 pz.

ACMNT2V 1 pz.

ACAPPT2V 1 pz.

A\* = altezza / height / hauteur / Höhe / alto B\* = larghezza / width / longueur / Breite / ancho art\* = articolo / model / modèl / Artikel / artículo  
I\* = interasse / pipe centres / distance entre depart et retour / Achsabstand / distancia entre las conexiones E\* = pagina / page / page / Seite / página  
L\* = contenuto acqua / content / volume / Inhalt / volumen E\* = elettrico / electrical / electric / elektrisch / eléctrico

Kcal = Watt x 0.860  
BTU = Watt x 3.413

Watt Δt 60° = Watt Δt 50° x 1.259  
Watt Δt 40° = Watt Δt 50° x 0.754  
Watt Δt 30° = Watt Δt 50° x 0.524  
Watt Δt 20° = Watt Δt 50° x 0.314

p max = 4 bar

Colori/ colours / couleurs / Farbe / colores

[ BIAN ] B standard  
T + 30%  
S + 30%  
[ RAL ] S + 30%  
RAL non inclusi in tabella  
special Ral colours  
couleurs Ral spéciales  
RAL Farbe nicht in der Tabelle inbegriffen  
colores RAL especiales

AVC0561\_  
AVC0562\_

Valvole incluse  
Valves are included in the price  
Valves incluses dans le prix  
Ventile im Preis inbegriffen  
Valvulas incluidas en el precio

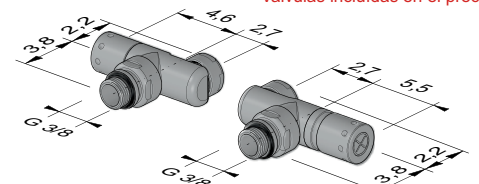

Per ordinare le mensole, specificare il numero di mensole (N) e l'interasse tra le stesse (S), che dovrà essere regolare e "maggiore o uguale" di 15 cm, partendo dal basso.

To order shelves, specify the number of shelves (N) and the distance between them (S). The centre distance must be even and "greater than or equal to" 15 cm from the base.

Pour commander les étagères, veuillez spécifier le numéro d'étagères (N) et l'écartement entre les étagères (S) qui devra être régulier et «supérieur ou égal» à 15 cm en partant du bas.

Bei der Bestellung der Regale bitte die Anzahl der Regale (N) und den Abstand (S) zwischen denselben angeben; dieser muss einheitlich sein und, von unten ausgehend, mindestens 15 cm betragen.

Para pedir las repisas especificar el número de repisas (N) y la distancia entre ellas (S), que tendrá que ser regular y "mayor o igual" a 15 cm desde abajo.

N =

S =

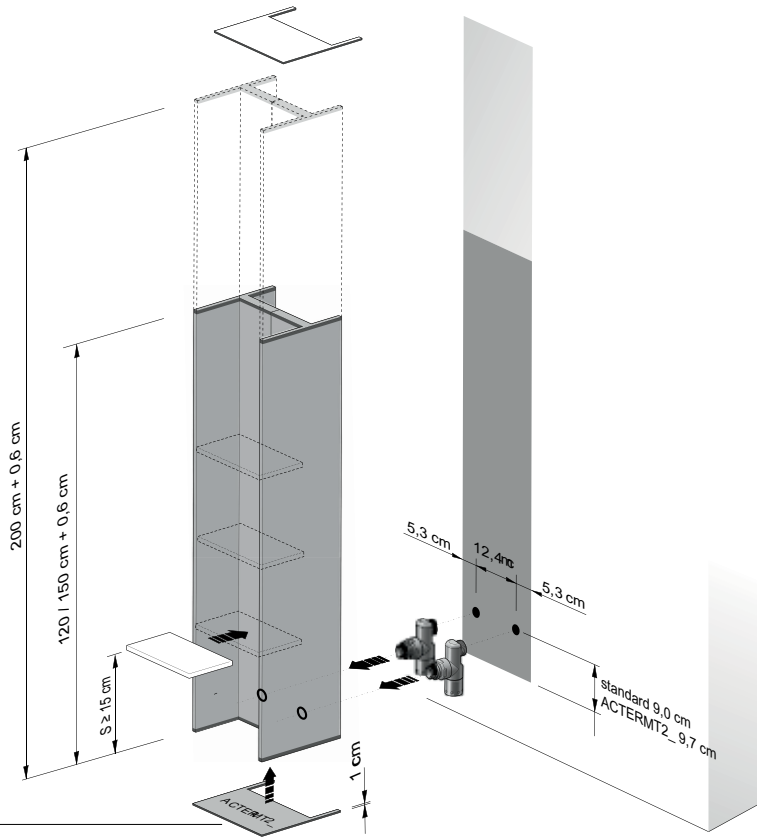

Terminale opzionale / Optional terminal  
Terminal en option / Optionaler Endheizkörper  
Terminal opcional

art*	A* cm	B* cm	l* cm
T200V120_	120.6	23	12.4
T200V150_	150.6	23	12.4
T200V200_	200.6	23	12.4

Per ordinare le mensole specificare il numero di mensole (N) e l'interasse tra le stesse (S), che dovrà essere regolare e "maggiore o uguale" di 15 cm, partendo dal basso.

To order shelves, specify the number of shelves (N) and the distance between them (S). The centre distance must be even and "greater than or equal to" 15 cm from the base.

Pour commander les étagères, veuillez spécifier le numéro d'étagères (N) et l'écartement entre les étagères (S) qui devra être régulier et «supérieur ou égal» à 15 cm en partant du bas.

Bei der Bestellung der Regale bitte die Anzahl der Regale (N) und den Abstand (S) zwischen denselben angeben; dieser muss einheitlich sein und, von unten ausgehend, mindestens 15 cm betragen.

Para pedir las repisas especificar el número de repisas (N) y la distancia entre ellas (S), que tendrá que ser regular y "mayor o igual" a 15 cm desde abajo.

N =

S =

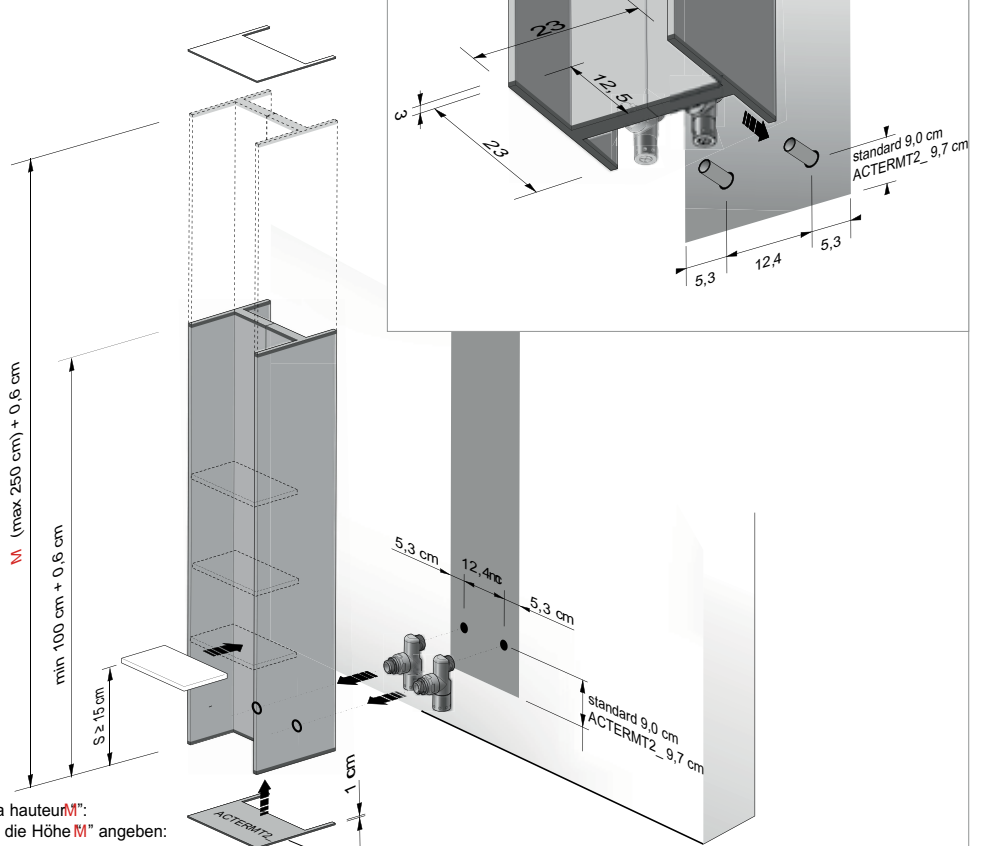

Per ordinare un radiatore su misura, specificare l'altezza "M":

To order a tailored radiator, specify height "M":

Pour commander un radiateur sur mesure, veuillez spécifier la hauteur "M":

Bei der Bestellung eines nach Maß angefertigten Heizkörpers die Höhe "M" angeben:

Para pedir un radiador a medida especificar la altura "M":

art* cm	M	A* cm	B* cm	l* cm	range
T200V (M)_		B= M + 0.6	23	12.4	100 -> 119
					121 -> 149
					151 -> 199
					201 -> 250

(es: M=138 cm --> art\*=T200V138\_ A\*=138.6 B\*=23 l\*=12.4 )

Terminale opzionale / Optional terminal  
Terminal en option / Optionaler Endheizkörper  
Terminal opcional

Informazioni tecniche aggiuntive p.26.  
Additional technical information p.26.  
Informations techniques supplémentaires p.26.  
Zusätzliche technische Informationen s.26.  
Informaciones técnicas adicionales p.26.



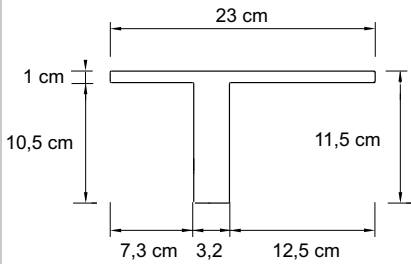

Sezione del Profilato a "T"  
 Section of the "T" shape  
 Découp du profilé en "T"  
 T" Profilschnitt  
 Porción del perfil "T"



T20 | ≥ 20 cm | ≥ 20 cm |  
 T1P | ≥ 10 cm | ≥ 10 cm |  
 T1M |

**T20, T1P, T1M**

Distanza minima per lato consigliata per l'installazione: 20 cm [10 cm].  
 Minimum distance per side recommended for installation: 20 cm [10 cm].  
 Distance minimale conseillée pour chaque côté pour l'installation: 20 cm [10 cm].  
 Der für den Einbau empfohlene Mindestseitenabstand beträgt: 20 cm [10 cm].  
 Distancia mínima por lado aconsejada para la instalación: 20 cm [10 cm].

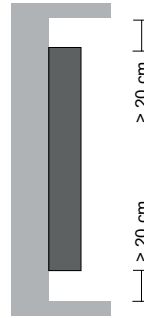

**T2V**

Distanza minima da pavimento e da soffitto per l'installazione: 20 cm.  
 Minimum distance from floor and ceiling for installation: 20 cm.  
 Distance minimale au sol et au plafond pour l'installation: 20 cm.  
 Für den Einbau soll der Mindestabstand vom Fußboden und von der Decke: 20 cm betragen.  
 Distancia mínima desde el suelo y desde el techo para la instalación: 20 cm.

**standard**

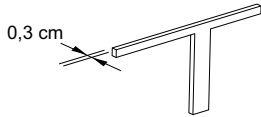

Il radiatore è disponibile nelle misure standard, da 120 cm, 150 cm e 200 cm, ed è disponibile anche su misura al centimetro, a partire da 100 cm fino a 250 cm. Alla misura richiesta va sempre aggiunto 0.6 cm per i terminali standard integrati o 2.0 cm per i terminali opzionali, se previsto per il modello scelto. Sia il terminale standard che quello opzionale sono disponibili unicamente nel colore del radiatore scelto.

Qu'ils soient standards ou en option, les terminaux ne sont disponibles que dans la couleur du radiateur choisi.

Der Heizkörper ist in den Standardmaßen von 120 cm, 150 cm und 200 cm, aber auch nach Zentimetern von 100 cm bis 250 cm nach Maß verfügbar. Zum angeforderten Maß werden stets 0.6 cm für die integrierten Standard-Endheizkörper oder 2.0 cm für die optionalen Endheizkörper hinzugerechnet, wenn dies für das gewählte Modell vorgesehen ist. Sowohl der standardmäßige, als auch der optionale Endheizkörper ist nur in der Farbe des gewählten Heizkörpers erhältlich.

**ACTERM2\_**

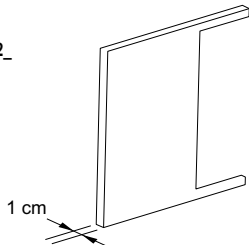

The radiator is available in standard sizes, 120 cm, 150 cm and 200 cm, and can also be tailored from 100 cm up to 250 cm. 0.6 cm is always added to the requested size for standard integrated terminals or 2.0 cm for optional terminals if specified for the selected model. Both the standard terminal and the optional terminal are available only in the colour of the selected radiator.

El radiador se encuentra disponible en las medidas estándar de 120 cm, 150 cm y 200 cm, y también se encuentra disponible a medida al centímetro a partir de 100 cm y hasta 250 cm. A la medida solicitada se tiene que añadir siempre 0.6 cm para los terminales estándar integrados o 2.0 cm para el terminal opcional si está previsto para el modelo seleccionado. Tanto el terminal estándar como el opcional se encuentran disponibles únicamente en el color del radiador seleccionado.

**ACMNT2V**

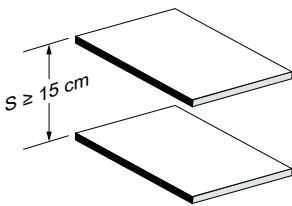

Nella versione T2V sono disponibili le mensole in legno finitura noce. In fase di ordine specificare il numero di mensole (N) e l'interasse tra le stesse (S), che dovrà essere regolare e "maggiore o uguale" a 15 cm partendo dal basso. Le mensole devono essere ordinate contestualmente al radiatore.

In der Version T2V sind Regale aus Nussholz verfügbar. Bei der Bestellung bitte die Anzahl der Regale (N) und den Abstand (S) zwischen denselben angeben; dieser muss einheitlich sein und, von unten ausgehend, mindestens 15 cm betragen. Die Regale müssen zusammen mit dem Heizkörper bestellt werden.

En la versión T2V se encuentran disponibles las repisas de madera con acabado nogal. Durante la fase del pedido especificar el número de repisas (N) y la distancia entre ellas (S), que tendrá que ser regular y "mayor o igual" a 15 cm desde abajo. Las repisas se tienen que pedir de forma contemporánea con el radiador.

Wooden shelves with a walnut finish are available for the T2V version. To order shelves, specify the number of shelves (N) and the distance between them (S). The centre distance must be even and "greater than or equal to" 15 cm from the base. Shelves must be ordered together with the radiator.

Dans la version T2V, les étagères sont disponibles en bois finition noyer. Au moment de la commande, veuillez spécifier le numéro d'étagères (N) et l'écartement entre les étagères (S) qui devra être régulier et « supérieur ou égal » à 15 cm en partant du bas. Les étagères doivent être commandées en même temps que le radiateur.

**ACAPPT2V**

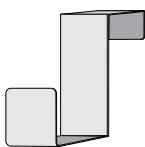

Nella versione T2V è disponibile un gancio porta accappatoio cromato, che può essere ordinato come accessorio anche successivamente all'installazione del radiatore. Nelle versioni con i terminali opzionali (ACTERM2\_), il gancio porta accappatoio deve essere ordinato contestualmente al radiatore.

In der Version T2V ist ein verchromter Bademantelhaken erhältlich, der als Zubehör auch nach dem Einbau des Heizkörpers bestellt werden kann. In der Version mit den optionalen Endheizkörpern (ACTERM2\_) muss der Bademantelhaken zusammen mit dem Heizkörper bestellt werden.

A chrome bathrobe hook is available for the T2V version. This hook can be ordered as an accessory following installation of the radiator. For the version with optional terminals (ACTERM2\_) the bathrobe holder must be ordered together with the radiator.

En la versión T2V se encuentra disponible un gancho perchero para albornoces cromado, que se puede pedir como accesorio incluso sucesivamente a la instalación del radiador. En las versiones con los terminales opcionales (ACTERM2\_), el gancho perchero para albornoces se tiene que pedir de forma contemporánea con el radiador.

Dans la version T2V, il existe un crochet porte-peignoir chromé qui peut être commandé en tant qu'accessoire, même après l'installation du radiateur. Dans les versions où les terminaux sont en option (ACTERM2\_), le crochet porte-peignoir doit être commandé en même temps que le radiateur.

9LZH[LYTPJH;=/ 6[W\[:=  
 7\PZZHUJL;=/LPaSLPZ\UN;=  
 7V[LUJPHm\_PTH;=

A* cm	watt Δt 50°	A* cm	watt Δt 50°
100	512	176	854
101	517	177	859
102	521	178	863
103	526	179	868
104	530	180	872
105	535	181	876
106	539	182	881
107	544	183	885
108	549	184	890
109	553	185	894
110	558	186	899
111	562	187	903
112	567	188	908
113	571	189	912
114	576	190	917
115	580	191	921
116	585	192	925
117	589	193	930
118	594	194	934
119	598	195	939
120	603	196	943
121	608	197	948
122	612	198	952
123	617	199	957
124	621	200	961
125	626	201	966
126	630	202	970
127	635	203	974
128	639	204	979
129	644	205	983
130	648	206	988
131	653	207	992
132	657	208	997
133	662	209	1 001
134	666	210	1 006
135	671	211	1 010
136	675	212	1 014
137	680	213	1 019
138	684	214	1 023
139	689	215	1 028
140	693	216	1 032
141	698	217	1 037
142	702	218	1 041
143	707	219	1 046
144	711	220	1 050
145	716	221	1 055
146	720	222	1 059
147	725	223	1 063
148	729	224	1 068
149	734	225	1 072
150	738	226	1 077
151	742	227	1 081
152	747	228	1 086
153	751	229	1 090
154	756	230	1 095
155	760	231	1 099
156	765	232	1 104
157	769	233	1 108
158	774	234	1 112
159	778	235	1 117
160	783	236	1 121
161	787	237	1 126
162	792	238	1 130
163	796	239	1 135
164	801	240	1 139
165	805	241	1 144
166	810	242	1 148
167	814	243	1 153
168	818	244	1 157
169	823	245	1 162
170	827	246	1 166
171	832	247	1 170
172	836	248	1 175
173	841	249	1 179
174	845	250	1 184
175	850		

:PZ[LTHKPÄZZHNNPV>HSSiYHJRL[Z:Z[uTLKLÄ\_H[PVU  
 :H[alLMLZ[PNUN:Z[LT:VWVY[LZ

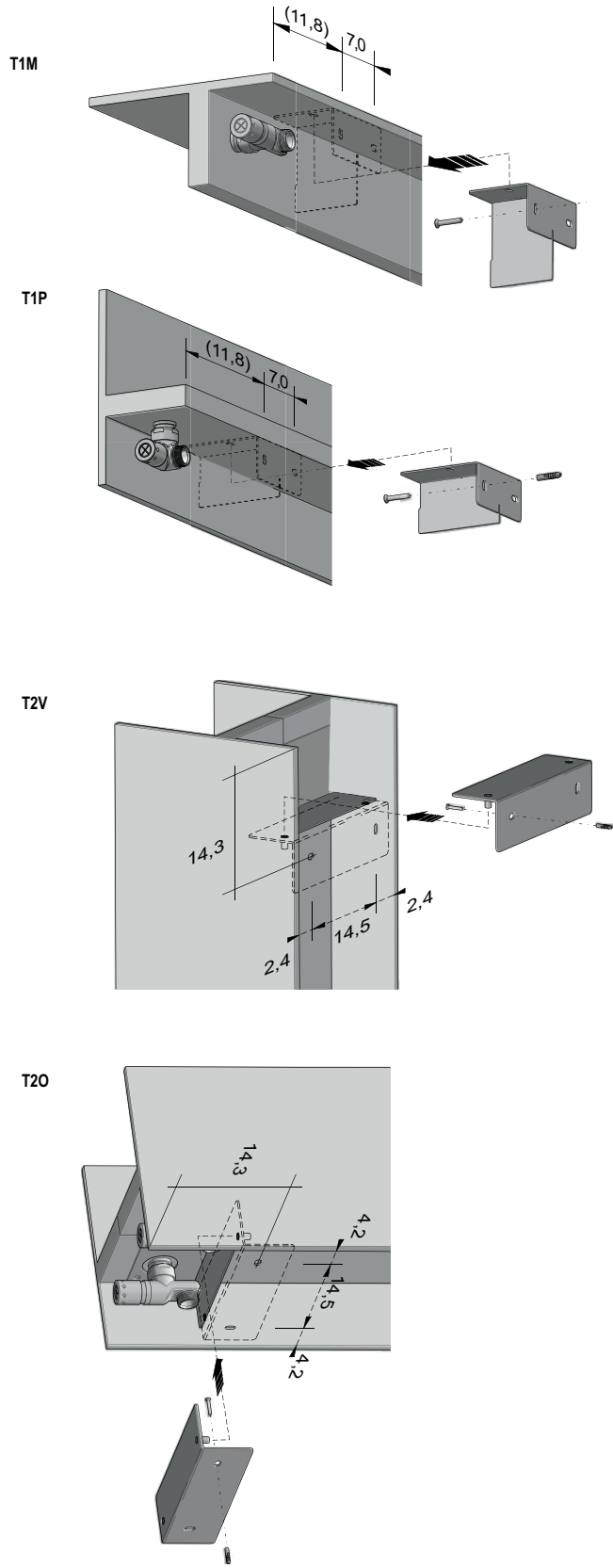

Tutte le misure indicate nel presente listino sono soggette ad una tolleranza di  $\pm 0.2$  cm.  
 All sizes indicated in this price list are subject to a tolerance of  $\pm 0.2$  cm.  
 Toutes les dimensions indiquées dans le présent catalogue sont sujettes à une tolérance de  $\pm 0.2$  cm.  
 Alle im vorliegenden Katalog angeführten Maße unterliegen einer Toleranz von  $\pm 0.2$  cm.  
 Todas las medidas indicadas en el presente catálogo están sometidas a una tolerancia de  $\pm 0.2$  cm.

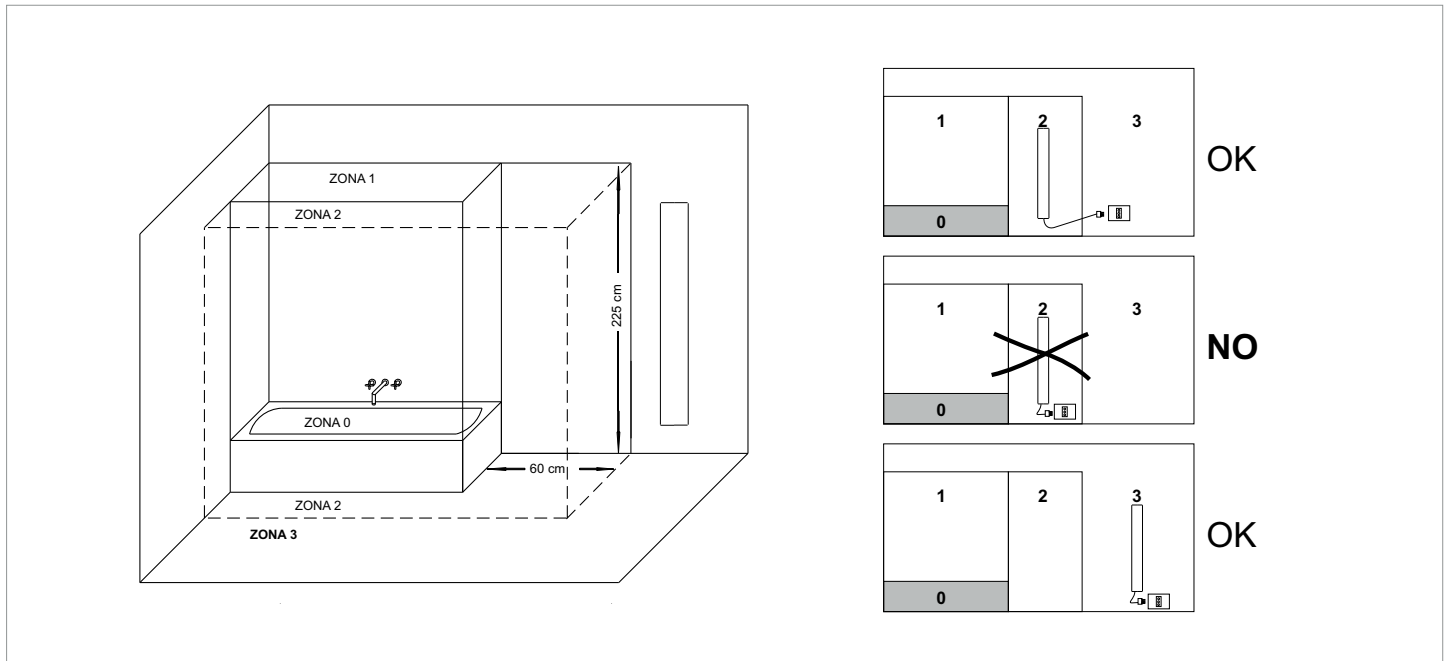

Allacciamento alla presa elettrica. La spina non viene fornita.  
 Si consiglia una presa comandata da un interruttore.  
 Connection to the junction-box. Junction-box is not supplied.  
 We suggest an On/Off switch  
 Branchement à la prise de courant. La pris de courant n'est pas fournie.  
 Nous conseillons une pris de courant contrôlée par un interrupteur.  
 Elektrischer Anschluss mit Steckdose. Die Steckdose wird nicht ausgestattet.  
 Man empfiehlt eine Steckdose mit Schalter.  
 Conexión al enchufe. El enchufe no está incluido.  
 Aconsejamos un enchufe con interrupto.

Allacciamento diretto alla rete con interruttore. Interruttore non fornito.  
 Direct connection with On/Off switch. On/Off switch is not supplied.  
 Branchement direct avec interrupteur. L'interrupteur n'est pas fourni.  
 Direkter Anschluss mit Schalter. Der Schalter wird nicht ausgestattet.  
 Conexión directa con interruptor. El interruptor no está incluido.

Allacciamento con cromotermostato wireless con ricevitore a radio frequenza.  
 Connection through wireless radio frequency receiver.  
 Branchement par chronotheostat sans fil avec recepteur à radiofréquence.  
 Anschluss mit Chronothermostat Wireless und Radiofrequenz Empfänger  
 conexión con termóstato sin hilos y receptor en radio frecuencia.

T2V

Cavo fornito di serie ( 190 cm ) senza spina  
 Cable supplied as standard (190 cm) without plug  
 Câble fourni en standard (190 cm) sans fiche  
 Kabel als Standard (190 cm) ohne Stecker geliefert  
 Cable suministrado de serie (190 cm), sin enchufe

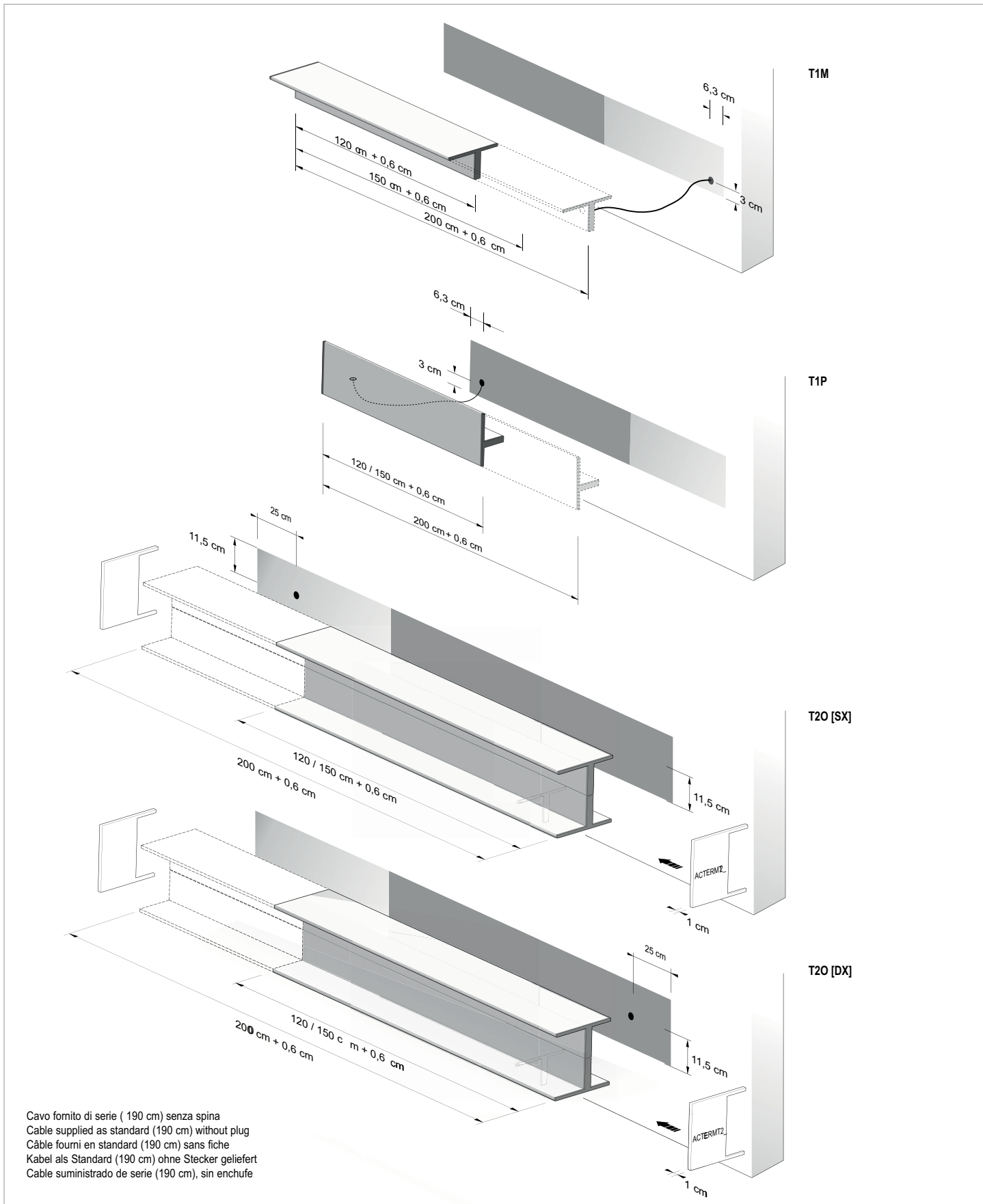

art\*  
**AVHCROM**

cronotermostato digitale per versione elettrica a radio frequenza / digital chronothermostat for electric version / chronothermostat digital pour version électrique avec radiofréquence / der digital Chronothermostat für elektrische Ausführung mit Radiofrequenz  
 cronotermostato digital para version eléctrica en radio frecuencia



art\*  
**AVHRICC**

ricevitore per cronotermostato digitale / receiver for digital chronothermostat  
 receveur pour chronothermostat digital  
 digital Chronothermostat Empfänger / receptor para cronotermostato digital

